

LFC24-3-R (-S) US



On-off, spring return fail-safe, reversible, floating point, 24V, Trane Voyager retrofit



Torque min. 35 in-lb, for control of air dampers

Application

For modulation or on-off control of dampers in HVAC systems. Actuator sizing should be done in accordance with the damper manufacturer's specifications.

The actuator is mounted directly to a damper shaft from 3/8" up to 1/2" in diameter by means of its universal clamp, 1/2" shaft centered at delivery. For shafts up to 3/4" use K6-1 accessory. The ZG-LFC114 universal mounting kit can be used with the LFC24-3-R US actuator for retrofit of the economizer section of the Trane Voyager unit.

Control is floating point from a triac or relay, or on-off from an auxiliary contact from a fan motor contactor, controller, or manual switch.

Operation

The LF series actuators provide true spring return operation for reliable fail-safe application and positive close-off on air tight dampers. The spring return system provides consistent torque to the damper with, and without, power applied to the actuator.

The LF series provides 95° of rotation and is provided with a graduated position indicator showing 0 to 95°.

The LFC24-3-R (-S) US uses a brushless DC motor which is controlled by an Application Specific Integrated Circuit (ASIC) and a microprocessor. The microprocessor provides the intelligence to the ASIC to provide a constant rotation rate. The ASIC monitors and controls the brushless DC motor's rotation and provides a digital rotation sensing function to prevent damage to the actuator in a stall condition. The actuator may be stalled anywhere in its normal rotation without the need of mechanical end switches. Power consumption is reduced in holding mode.

The LFC24-3-S US version is provided with 1 built-in auxiliary switch. This SPDT switch is provided for safety interfacing or signaling, for example, for fan start-up. The switching function is adjustable between 0° and 95°. The auxiliary switch in the LFC24-3-S US is double insulated so an electrical ground is not necessary.

Technical Data	LFC24-3-R US
Power supply	24 VAC ± 20% 50/60 Hz 24 VDC ± 10%
Power consumption	running: 2.5 W ; holding: 1 W
Transformer sizing	5 VA (class 2 power source)
Electrical connection	3 ft, plenum rated cable 4 male spade connectors
Overload protection	electronic throughout 0 to 95° rotation
Input impedance	1000 Ω (0.6W) control inputs
Angle of rotation	max. 95°, adjust. with mechanical stop
Torque	35 in-lb [4 Nm]
Direction of rotation	spring: reversible with cw/ccw mounting motor: reversible with built-in switch
Position indication	visual indicator, 0° to 95° (0° is spring return position)
Running time	motor: 90 sec constant, independent of load spring: < 25 sec @ -4°F to +122°F [-20°C to +50°C] < 60 sec @ -22°F [-30°C]
Humidity	5 to 95% RH non-condensing
Ambient temperature	-22°F to +122°F [-30°C to +50°C]
Storage temperature	-40°F to +176°F [-40°C to +80°C]
Housing	NEMA type 2 /IP54
Housing material	zinc coated metal
Agency listings	UL 873 listed; CSA C22.2 No.24 certified, CE
Noise level	max: running < 30 db (A) spring return 62 db (A)
Servicing	maintenance free
Quality standard	ISO 9001
Weight	3.1 lbs (1.40 kg.)

Technical Data	LFC24-3-S US
Auxiliary switch	1 x SPDT 6A (1.5A) @ 250 VAC, UL listed adjustable 0° to 95° (double insulated)
Electrical Connection	3 ft, 18 GA appliance cables (2) 1/2" conduit connector
Weight	3.6 lbs (1.45 kg.)

Dimensions [All numbers in brackets are in millimeters.]

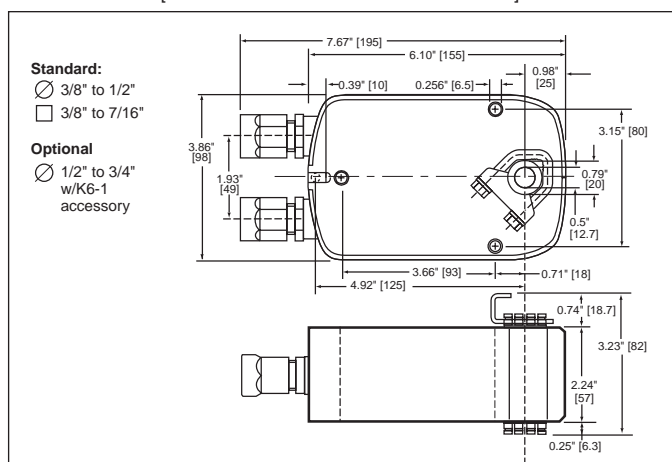

G20492-IG-Subject to change. © Belimo Aircontrols (USA), Inc.

Accessories

- AV 10-18 Shaft extension (K6-1 is required)
- IND-LF Damper position indicator
- K6-1 Universal clamp for up to 3/4" diameter shafts
- KH-LF Crankarm for up to 1/2" round shaft
- Tool-06 8mm and 10 mm wrench
- ZG-LF2 Crankarm adaptor kit for LF
- ZG-112 Mounting bracket for Honeywell Mod IV, M6415 type actuators, and new installations
- ZG-LF112 Crankarm adaptor kit for Honeywell Mod IV, M6415 type actuators, and new installations
- ZG-LFC114 Used with LFC24-3-R US, mounting bracket kit for Trane Voyager economizer actuator retrofit. Kit includes mounting bracket and installation hardware.**
- ZS-100 Weather shield (metal)
- ZS-150 Weather shield (polycarbonate)
- ZS-260 Explosion-proof housing

Note: When using LFC24-3-R (-S) US actuators, only use accessories listed on this page.

Note: For On-Off control wiring please see LF24-3 US wiring diagram. "On-Off control of LF24-3 (-S) US" page 56.

Note: For Floating point control wiring, Triac source, sink or wiring with separate power supplies please see page 56 for correct wiring.

Note: Please consult equipment and/or controller manufacturers documentation to ensure compatibility. If you are unsure send controller specifications to Belimo Aircontrols for evaluation.

Wiring Diagrams

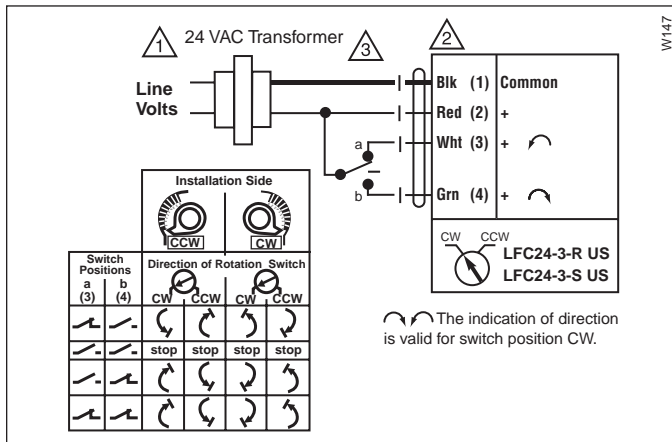

Floating point control of LF24-3... US

Notes:

- 1 Provide overload protection and disconnect as required.
- 2 Actuators may be connected in parallel. Power consumption must be observed.
- 3 No ground connection is required.
- 6 For end position indication, interlock control, fan startup, etc., LFC24-3-S US incorporates one built-in auxiliary switch: 1 x SPDT, 6A (1.5A) @250 VAC, UL listed, adjustable 0° to 95°.
- 7 Meets UL and CSA requirements without the need of an electrical ground connection.

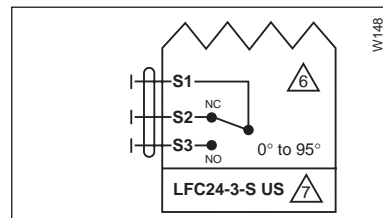

Auxiliary switch of LFC24-3-S US

LFC24-3-R (-S) US Typical Specification

Floating point, on-off spring return damper actuators shall be direct coupled type which require no crankarm and linkage and be capable of direct mounting to a shaft up to a 3/4" diameter and center a 1/2" shaft. The actuators must be designed so that they may be used for either clockwise or counterclockwise fail-safe operation. Actuators shall have an external direction of rotation switch to reverse control logic. Actuators shall use a brushless DC motor and be protected from overload at all angles of rotation. If required, 1 SPDT auxiliary switch shall be provided having the capability of being adjustable. Actuators with auxiliary switch must be constructed to meet the requirements for Double Insulation so an electrical ground is not required to meet agency listings. Run time shall be constant and independent of torque. Actuators shall be UL listed and CSA certified, have a 5 year warranty, and be manufactured under ISO 9001 International Quality Control Standards. Actuators shall be as manufactured by Belimo.

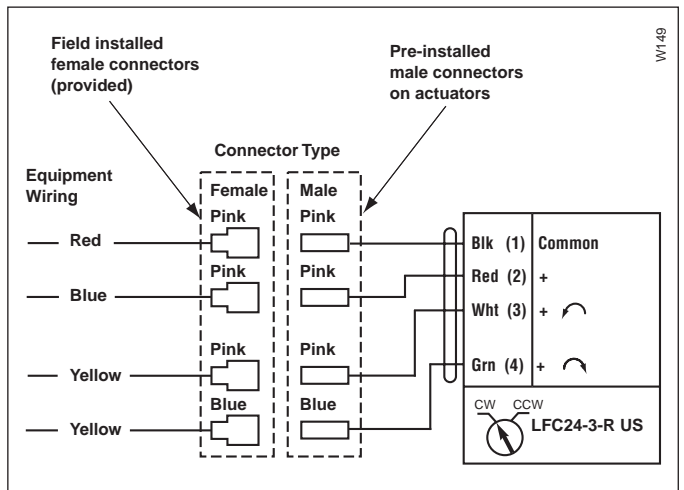

Wiring LFC24-3-R US

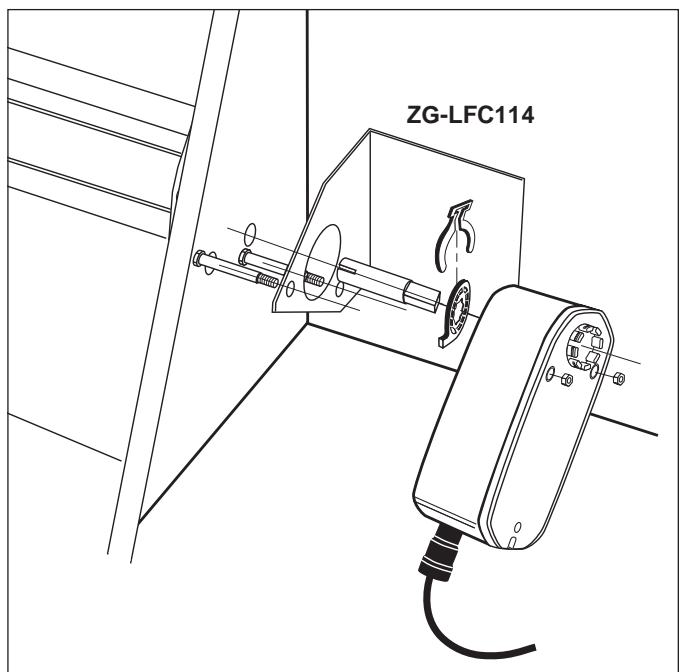

Retrofit solution installation