

LF24-SR-E US



Proportional damper actuator, 24 V for 2 to 10 VDC (or 4 to 20 mA) control signal or 3-position on/off control, with minimum position potentiometer. Output signal of 2 to 10 VDC for position indication.



- Torque min. 35 in-lb, for control of air dampers
- Built-in adjustable min-position for 3-position and proportional control

Application

For proportional control with minimum position setpoint, or three position control of dampers in HVAC systems. Actuator sizing should be done in accordance with the damper manufacturer's specifications.

The actuator is mounted directly to a damper shaft from 3/8" up to 1/2" in diameter by means of its universal clamp, 1/2" shaft centered at delivery. For shafts up to 3/4" use K6-1 accessory. A crank arm and several mounting brackets are available for applications where the actuator cannot be direct coupled to the damper shaft.

The actuator operates in response to 24 VAC on wire 2 or 3, which allows the LF24-SR-E US to retrofit or replace Honeywell® M8405A actuators.

Operation

The LF series actuators provide true spring return operation for reliable fail-safe application and positive close-off on air tight dampers. The spring return system provides constant torque to the damper with, and without, power applied to the actuator. The LF series provides 95° of rotation and is provided with a graduated position indicator showing 0 to 95°.

The LF24-SR-E US uses a brushless DC motor which is controlled by an Application Specific Integrated Circuit (ASIC) and a microprocessor. The microprocessor provides the intelligence to the ASIC to provide a constant rotation rate and to know the actuator's exact position. The ASIC monitors and controls the brushless DC motor's rotation and provides a digital rotation sensing function to prevent damage to the actuator in a stall condition. The actuator may be stalled anywhere in its normal rotation without the need of mechanical end switches. Power consumption is reduced in holding mode.

See wiring diagrams for LF24-SR-E US for more details on 3-position control.

Installation

Refer to LF Section of the Standard Actuation and Accessories, Technical Documentation.

Honeywell® is a trademark of Honeywell Inc.

Dimensions [All numbers in brackets are in millimeters.]

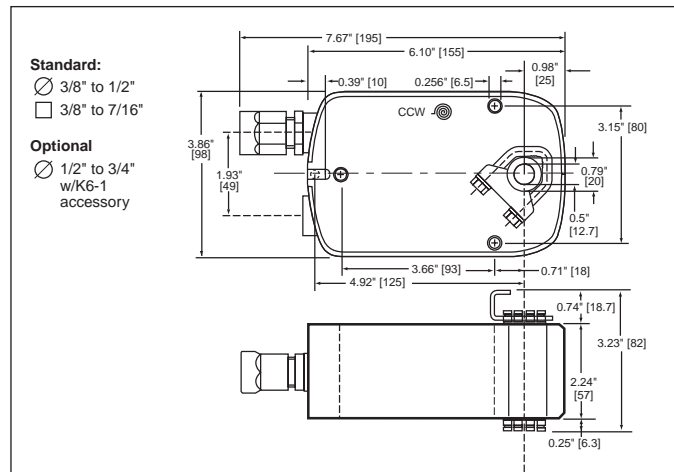

Technical Data	LF24-SR-E US
Power supply	24 VAC ± 20% 50/60 Hz, 24 VDC ± 10%
Power consumption	running: 2.5 W; holding: 1 W
Transformer sizing	5 VA (class 2 power source)
Electrical connection	3 ft, plenum rated cable 1/2" conduit connector
Overload protection	electronic throughout 0 to 95° rotation
Control signal	Y 0 to 10 VDC, 0 to 20 mA, or 24 VAC for 3-position on/off control
Input impedance	100 kΩ
Operating range Y	2 to 10 VDC, 4 to 20mA between 0% and 100%
Feedback output U	2 to 10 VDC (max. 0.7 mA) for 95°
Angle of rotation	max. 95°, adjust. with mechanical stop
Torque	35 in-lb [4 Nm]
Override function	Minimum, Open, Closed via spring Min-position adjusts on actuator cover between 0 and 100% (scaled 0 to 1)
Direction of rotation	spring: reversible with cw/ccw mounting motor: reversible with built-in switch
Position indication	visual indicator, 0° to 95° (0° is spring return position)
Running time	motor: 150 sec constant, independent of load spring: < 25 sec @ -4°F to +122°F [-20°C to +50°C] < 60 sec @ -22°F [-30°C]
Humidity	5 to 95% RH non-condensing
Ambient temperature	-22°F to +122°F [-30°C to +50°C]
Storage temperature	-40°F to +176°F [-40°C to +80°C]
Housing	NEMA type 2 / IP54
Housing material	zinc coated metal
Agency listings	UL 873 listed; CSA C22.2 No. 24 certified, CE
Noise level	max: running < 30 db (A) spring return 62 db (A)
Servicing	maintenance free
Quality standard	ISO 9001
Weight	3.2 lbs (1.45 kg.)

Proportional damper actuator, 24 V for 2 to 10 VDC (or 4 to 20 mA) control signal or 3-position on/off control, with minimum position potentiometer. Output signal of 2 to 10 VDC for position indication.

Accessories

- AV 10-18 Shaft extension (K6-1 is required)
- IND-LF Damper position indicator
- K6-1 Universal clamp for up to 3/4" diameter shafts
- KH-LF Crankarm for up to 1/2" round shaft
- Tool-06 8mm and 10 mm wrench
- ZG-LF2 Crankarm adaptor kit for LF
- ZG-112 Mounting bracket for replacing Honeywell Mod IV, M6415 and M8405 type actuators, and new installations
- ZG-LF112 Crankarm adaptor kit for replacing Honeywell Mod IV, M6415 and M8405 type actuators, and new installations
- ZG-113 Mounting bracket kit for Honeywell W7459 logic module
- ZG-ECON1 Mounting bracket kit for Honeywell M8405 economizer actuator retrofit and new installations
- ZS-100 Weather shield (metal)
- ZS-150 Weather shield (polycarbonate)

Note: When using LF24-SR-E US actuators, only use accessories listed on this page.

Wiring diagrams

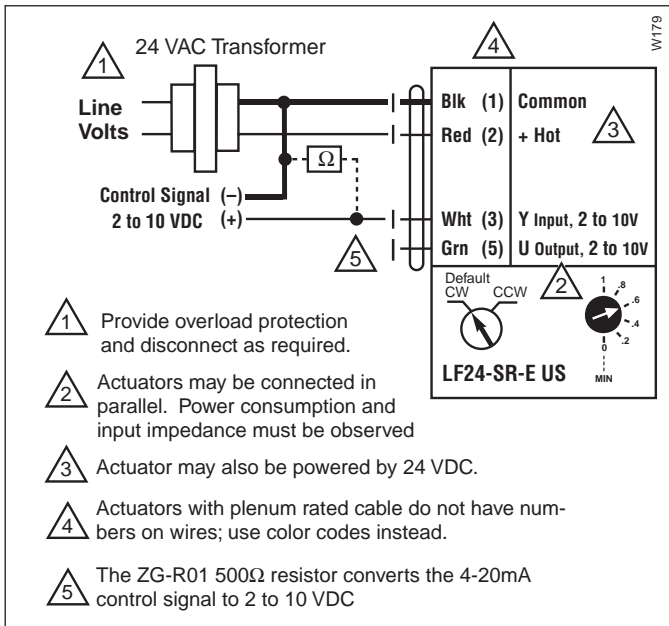

2 to 10 VDC control of LF24-SR-E US

Three-Position Control Signals			
Switch A	Wire 2-Red (x)	Wire 3-White (D)	Position
Open**	Any	Any	Closed (via spring)
Closed	24 VAC	Open	Mid-position*
Closed	Open	24 VAC	Full Open*
Closed	24 VAC	24 VAC	Full Open*

* Desired position achieved by driving actuator with motor.
 ** An example would be to interlock the actuator power supply with the fan motor starter.

LF24-SR-E US Typical Specification

Spring return control damper actuators shall be direct coupled type which require no crankarm and linkage and be capable of direct mounting to a shaft up to a 3/4" diameter and center a 1/2" shaft. Actuator shall deliver a minimum output torque of 35 in-lbs. The actuator must provide proportional damper control in response to a 2 to 10 VDC or, with the addition of a 500Ω resistor, a 4 to 20mA control input from an electronic controller. Actuator must have a built-in minimum position potentiometer. During 3-position control, the actuator shall drive to minimum position with 24 VAC on wire 2 and drive full open with 24 VAC on wire 3. Actuators shall use a brushless DC motor controlled by a microprocessor and be protected from overload at all angles of rotation. Run time shall be constant, and independent of torque. A 2 to 10 feedback signal shall be provided for position feedback or master-slave applications. The actuator must be designed so that they may be used for either clockwise or counterclockwise failsafe operation. Actuators shall be UL listed and CSA certified, have a 5 year warranty, and be manufactured under ISO 9001 International Quality Control Standards. Actuators shall be as manufactured by Belimo.

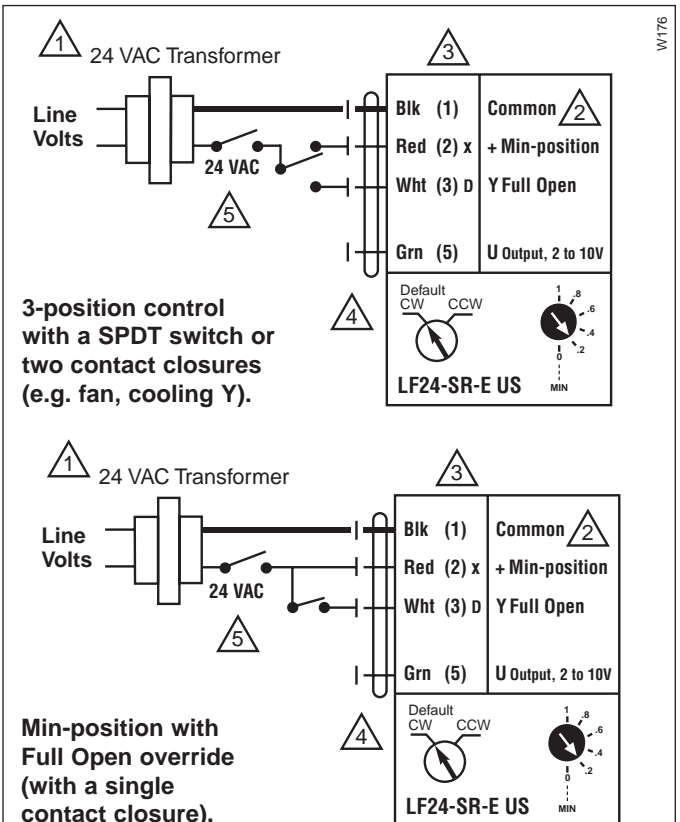

Notes:

- 1** Provide overload protection and disconnect as required.
- 2** Min-position is adjustable from 0 to 100% with a potentiometer on the actuator cover.
- 3** Actuators with plenum rated cable do not have numbers on wires; use color codes instead.
- 4** For 3-position control set direction of rotation to CW (Default).
- 5** Switch A, actuator spring returns when open (e.g., fan interlock).

Application of the LF24-SR-E US with minimum position potentiometer

The LF24-SR-E US is the newest addition to the LF-series product range featuring dual functionality. A minimum position potentiometer has been built into the actuator for cost effective proportional and three position applications, e.g. economizer dampers in rooftop units.

Proportional control with minimum position

Minimum position is adjustable using the built-in potentiometer on the cover of the LF24-SR-E US. The minimum position can be adjusted anywhere over the full 0 to 95° range of the actuator. A 2 to 10 VDC input proportionally controls the actuator to the set-point position. The actuator electronics see both the 2 to 10 VDC input and the input signal from the potentiometer (minimum position setting). The actuator's electronics select between the higher of these two signals. Therefore, the actuator moves to the position of the higher signal, which is the same operating characteristic the Belimo –SR actuators exhibit with the Belimo SGA24 and SGF24 positioners.



LF24-SR-E US operates as follows:

1. Set desired minimum position (Example 20%), while leaving the direction of rotation switch in the CW (default) position.
2. With power applied to wire 2 (red), the actuator will maintain the desired minimum position.
3. Applying a signal higher than that set by the minimum position potentiometer. In this example the input DC voltage must be greater than 3.6 VDC to move the actuator toward full open.
4. Changing the position of the direction of rotation switch to CCW will reverse the actuator's control logic. If only the position of the direction of rotation switch is changed, then the actuator will move from 20% to 80%. The scale is now reverse from the default (e.g. 10VDC moves the actuator to 0).
5. Typically, power to the actuator is interlocked with the fan relay, which causes the actuator to spring return closed if the fan de-energizes.

Control Accuracy and Stability

LF24-SR-E US actuators have built-in brushless DC motors which provide better accuracy and longer service life.

The LF24-SR-E US actuators are designed with a unique non-symmetrical deadband. The actuator follows an increasing or decreasing control signal with a 80 mV resolution. If the signal changes in the opposite direction, the actuator will not respond until the control signal changes by 250 mV. This allows these actuators to track even the slightest deviation very accurately, yet allowing the actuator to "wait" for a much larger change in control signal due to control signal instability.

LF Actuator responds to a 80 mV signal when not changing direction from stop position.

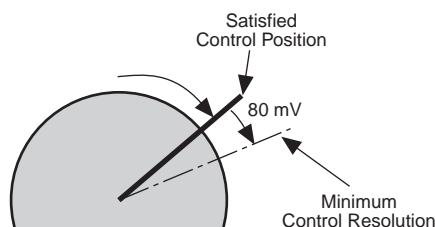

LF Actuator responds to a 250 mV signal when reversing direction from stop position.

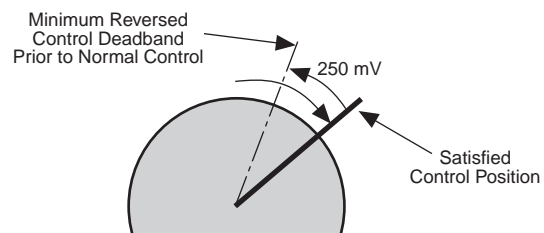

Three-Position control using the LF24-SR-E US

By applying the LF24-SR override functionality and the new minimum position potentiometer, it is possible to achieve simple three-position control with the LF24-SR-E US.

1. Set desired minimum position (Example 20%), while leaving the direction of rotation switch in the CW (default) position. The direction of rotation switch does not need to be changed for three-position control, because direction of rotation can be changed by flipping the actuator.
2. With 24 VAC power applied across wire 1 (black) and 2 (red), the actuator will maintain minimum position.
3. Applying 24 VAC power across wire 1 (black) and 3 (white) overrides the minimum position and moves the actuator to Full Open.
4. With no power applied to actuator, it will spring return (fail-safe) closed.
5. Typically, power to the actuator is interlocked with the fan relay, which causes the actuator to spring return closed if the fan de-energizes.

Features of the Belimo Three-Position Solution

The LF24-SR-E US will:

- Direct couple to the damper shaft between 3/8" and 3/4" diameter for reduced installation cost.
- Spring return in either CW or CCW direction depending on mounting orientation of the actuator. This feature eliminates the need to select a specific model with correct spring return direction.
- Spring returns in <25 seconds @ -4° to +122°F.
- Increase minimum torque output to 35 in-lbs for 40% more torque than other 3-position actuator solutions.
- Drive to the adjustable minimum position from either the fully Open or Closed position using its brushless DC motor for improved reliability. Spring returns only during power loss.
- Drive full stroke in 150 seconds.
- Output a 2 to 10 VDC signal for position feedback
- Control a damper proportionally between minimum position and full open (2 to 10 VDC input) for additional applications.
- Have dual (3-position and proportional control) wiring diagrams on actuator label for clear and easy wiring in the field.
- Consumes only 2.5 W driving to setpoint and 1 W to hold position, lower than actuators using AC motor technology.

Replacing an M8405 actuator

The three-position control functionality of the LF24-SR-E US allows direct replacement of a Honeywell M8405A foot mounted economizer actuator.

Mounting

For non-direct coupled applications use the ZG-ECON1 accessory kit, which includes the KH-LF crankarm, ZG112 bracket and logic module bracket (20477-00001). The ZG-112 aligns the plane of the crankarm with that of the Honeywell M8405A and has at least two mounting holes that match the M8405A foot pattern. The logic module bracket allows for attachment to the end of the LF24-SR-E US actuator. It provides for installation flexibility to place the module where space is available.

Wiring

For proper control logic wiring always refer to the controller manufacturer's documentation. See the Product Documentation Standard Actuation and Accessories for proper three position wiring diagram Belimo wiring diagram, page 63.

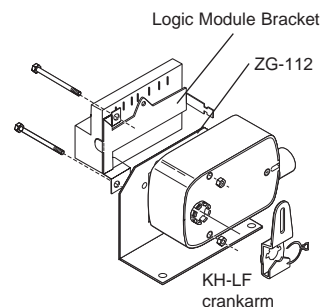

ZG-LF112 Crankarm adaptor kit

- Includes bracket and KH-LF crankarm.
- Bracket and crankarm for replacement of Honeywell M8405 actuators.