

AM24-PC US



Proportional damper actuator, non-spring return, direct coupled,
24 V, for 0 to 20 V phasecut control signal



AM24-PC US

Technical Data	AM24-PC US
Power supply	24 VAC, $\pm 20\%$, 50/60 Hz 24 VDC, $\pm 10\%$
Power consumption	running: 2.5 W; holding: 1.2 W
Transformer sizing	5 VA (Class 2 power source)
Operating range Y	0 to 10 V, phasecut
Input impedance	8k Ω (50 mW)
Feedback output 'U'	2 to 10 VDC, 0.5 mA max
Electrical connection	3 ft, 18 GA, appliance cable, 1/2" conduit connector
Overload protection	electronic throughout 0 to 95° rotation
Torque	min 160 in-lb (18 Nm)
Direction of rotation	reversible with switch CW/CCW CW with a decrease in voltage CCW with a decrease in voltage
Position indication	clip on indicator
Manual override	external push button
Angle of rotation	0 to 95°, adjust with mechanical stops
Running time	150 secs. constant, independent of load
Run time stability	$\pm 5\%$
Humidity	5 to 95% RH, non-condensing
Operating temperature	-22 to +122° F (-30 to +50° C)
Storage temperature	-40 to +176° F (-40 to +80° C)
Housing	NEMA 2 (IP54 with cable entry down)
Housing material	UL 94-5V (flammability rating)
Noise level	less than 45 dB (A)
Agency listings	UL 873 listed, CSA C22.2 No.24 certified, CE
Quality standard	ISO 9001
Servicing	maintenance free
Weight	2.8 lbs. (1.3kg.)

Torque min. 160 in-lb, for control of air dampers.

Application

For proportional modulation of dampers in HVAC systems. Actual actuator sizing should be done in accordance with the damper manufacturer's specifications.

The actuator is mounted directly to a damper shaft up to 1.05" in diameter by means of its universal clamp. A crankarm and several mounting brackets are available for applications where the actuator cannot be direct coupled to the damper shaft.

Operation

The actuator operates in response to 0 to 10 V phasecut input from an electronic controller or positioner. A 2 to 10 VDC feedback signal is provided for position indication or master-slave applications.

The actuator has a constant running time of 150 seconds. A functional test of the actuator-damper assembly may be done by pressing in the manual override button, this will activate the actuators test mode and cycle the actuator fully closed and back to control point. The microprocessor will correct for compression of tight close-off gaskets with age, providing the actuator is not on its mechanical stops.

A 2 to 10 VDC feedback (U) is provided with full 8 volt output range proportional to the operational rotation of the damper. A digital rotation sensing circuit protects the actuator in a stall anywhere in its 95° operating range without the need of limit switches. Add on auxiliary switches are easily fastened directly onto the actuator body for signalling and switching functions.

Dimensions [All numbers in brackets are in millimeters.]

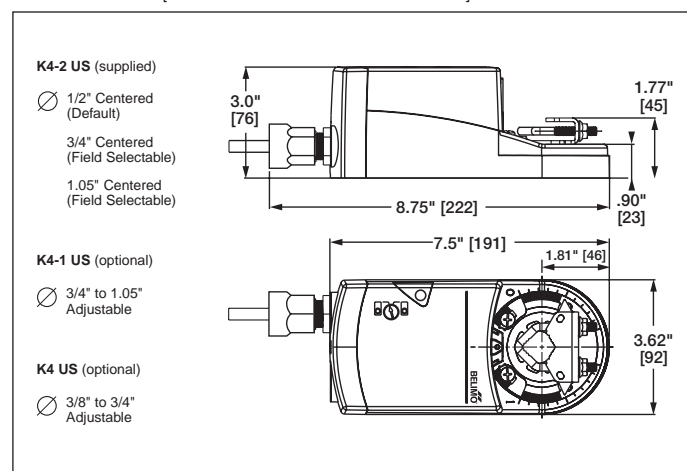

Proportional damper actuator, non-spring return, direct coupled, 24 V, for 0 to 20 V phasecut control signal

Accessories

AV 1	Damper shaft extension for AM
AV10-18	Universal shaft extension
K4 US	Universal clamp for 3/8" to 3/4" shafts
K4-1 US	Clamp for 3/4" to 1.05" jackshafts
K4-H	Hex shaft clamp, for 3/8"-5/8" shafts
KH-AM	Crankarm
SA1 US, SA2 US	Auxiliary switches
PA... US	140 Ω, 500 Ω, 1000 Ω, 2800 Ω feedback potentiometers
PTA-250	Pulse width modulation interface
Tool-06	8mm and 10 mm wrench
SGA24	Min. and/or man. positioner in NEMA 4 housing
SGF24	Min. and/or man. positioner for flush panel mounting
ZG-R01	500Ω resistor for 4 to 20 mA control signal
ZA-AM US	SM to AM retrofit bracket
ZG-AM US	Crank arm adaptor kit
ZG-100	Mounting bracket
ZG-101	Mounting bracket
ZG-103	Mounting bracket
ZG-104	Mounting bracket
ZS-100	Weather shield
ZS-150	Weather shield
ZS-260	Explosion-proof housing
ZS-300	NEMA 4X housing

AM24-PC US - Typical Specification:

Control damper actuators shall be electronic direct coupled type which require no crank arm and linkage and be capable of direct mounting to a jackshaft up to a 1.05" diameter. Actuators shall be UL and CSA listed, have a 5 year warranty, and be manufactured under ISO 9001 International Quality Control Standards. The actuator must provide proportional damper control in response to a 0 to 10 V phasecut input from an electronic controller or positioner. Actuators shall have reversing switch and gear disengagement button on the cover, and be electronically protected from overload at all angles of rotation. Actuators shall respond to 2 to 10VDC output relative to position regardless of the amount of damper rotation. Run time shall be constant and independent of torque. A 2 to 10 VDC feedback signal shall be provided for position indication or master-slave applications. Actuators shall be as manufactured by Belimo.

NOTE: When using AM24-PC US actuators, use only the accessories listed on this page.

AM

Wiring diagrams

