

# AF24-SR US



Proportional damper actuator, spring return failsafe, 24 V for 2 to 10 VDC and 4 to 20 mA control signal. Output signal of 2 to 10 VDC for position indication



**Torque min. 133 in-lb, for control of air dampers**

## Application

For proportional modulation of dampers in HVAC systems. Actuator sizing should be done in accordance with the damper manufacturer's specifications.

The actuator is mounted directly to a damper shaft up to 1.05" in diameter by means of its universal clamp. A crankarm and several mounting brackets are available for applications where the actuator cannot be direct coupled to the damper shaft.

The actuator operates in response to a 2 to 10 VDC, with the addition of a 500Ω resistor, a 4 to 20 mA control input from an electronic controller or positioner. A 2 to 10 VDC feedback signal is provided for position indication or master-slave applications.

## Operation

The AF series actuators provide true spring return operation for reliable fail-safe application and positive close-off on air tight dampers. The spring return system provides constant torque to the damper with, and without, power applied to the actuator.

The AF series provides 95° of rotation and is provided with a graduated position indicator showing 0 to 95°. The AF has a unique manual positioning mechanism which allows the setting of any damper position within its 95° of rotation. The actuator is shipped at +5° position (5° from full fail-safe) to provide automatic compression against damper gaskets for tight shut-off. When power is applied, the manual mechanism is released and the actuator drives toward the full fail-safe position. The actuator will memorize the angle where it stops rotating and use this point for its zero position for its normal control operations. The manual override can also be released physically by the use of a crank supplied with the actuator.

The AF uses a brushless DC motor which is controlled by an Application Specific Integrated Circuit (ASIC) and a microprocessor. The microprocessor provides the intelligence to the ASIC to provide a constant rotation rate and to know the actuator's exact zero position. The ASIC monitors and controls the brushless DC motor's rotation and provides a digital rotation sensing function to prevent damage to the actuator in a stall condition. The actuator may be stalled anywhere in its normal rotation without the need of mechanical end switches.

Technical Data	AF24-SR US
Power supply	24 VAC ± 20% 50/60 Hz 24 VDC ± 10%
Power consumption	running: 6 W ; holding: 2 W
Transformer sizing	10 VA (class 2 power source)
Electrical connection	3 ft, 18 GA appliance cable 1/2" conduit connector
Overload protection	electronic throughout 0 to 95° rotation
Operating range Y	2 to 10 VDC, 4 to 20 mA
Input impedance	100 kΩ (0.1 mA), 500Ω
Feedback output U	2 to 10 VDC (max. 0.5 mA) for 95°
Angle of rotation	mechanically limited to 95°
Torque	133 in-lb [15 Nm] constant
Direction of rotation	spring: reversible with cw/ccw mounting motor: reversible with built-in switch
Position indication	visual indicator, 0° to 95° (0° is spring return position)
Manual override	3mm hex crank (shipped w/actuator)
Running time	150 sec. constant, independent of load, spring return < 20 sec
Humidity	5 to 95% RH non-condensing
Ambient temperature	-22°F to +122°F [-30°C to +50°C]
Storage temperature	-40°F to +176°F [-40°C to +80°C]
Housing	NEMA type 2 / IP54
Housing material	zinc coated metal
Agency listings	UL 873 listed, CSA C22.2 No. 24 certified
Noise level	max. 45 dB (A)
Servicing	maintenance free
Quality standard	ISO 9001
Weight	6.0 lbs (2.7 kg.)

## Dimensions [All numbers in brackets are in millimeters.]

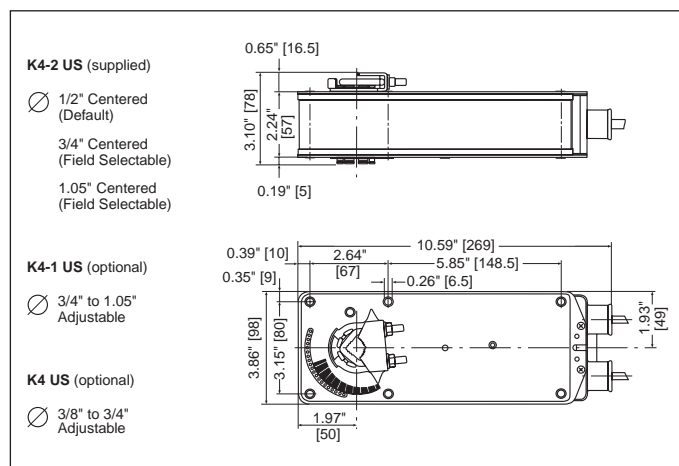

Proportional damper actuator, spring return failsafe, 24 V for 2 to 10 VDC and 4 to 20 mA control signal. Output signal of 2 to 10 VDC for position indication

**Accessories**

AV 10-18	Shaft extension
IND-AF2	Damper position indicator
K4 US	Universal clamp for 3/8" to 3/4" shafts
K4-1 US	Universal clamp for up to 1.05" dia jackshafts
K4-H	Universal clamp for hexshafts 3/8" to 5/8"
KH-AF	Crankarm for up to 3/4" round shaft (Series 2)
KH-AF-1	Crankarm for up to 1.05" jackshaft (Series 2)
KH-AFV	V-bolt kit for KH-AF and KH-AF-1
Tool-06	8mm and 10 mm wrench
SGA24	Min. and/or man. positioner in NEMA 4 housing
SGF24	Min. and/or man. positioner for flush panel mounting
ZG-R01	500Ω resistor for 4 to 20 mA control signal
ZG-HTR	Thermostat/Heater Kit
ZDB-AF2	Angle of rotation limiter
ZG-100	Universal mounting bracket
ZG-101	Universal mounting bracket
ZG-102	Multiple actuator mounting bracket
ZG-103	Universal mounting bracket
ZG-104	Universal mounting bracket
ZG-106	Mounting bracket for Honeywell® Mod IV replacement or new crankarm type installations
ZG-107	Mounting bracket for Honeywell® Mod III or Johnson® Series 100 replacement or new crankarm type installations
ZG-108	Mounting bracket for Barber Colman® MA 3../4., Honeywell® Mod III or IV or Johnson® Series 100 replacement or new crankarm type installations
ZG-AF US	Crankarm adaptor kit for AF/NF
ZG-AF108	Crankarm adaptor kit for AF/NF
ZS-100	Weather shield (metal)
ZS-150	Weather shield (polycarbonate)
ZS-260	Explosion-proof housing
ZS-300	NEMA 4X housing

**AF24-SR US Typical Specification**

Spring return control damper actuators shall be direct coupled type which require no crankarm and linkage and be capable of direct mounting to a jackshaft up to a 1.05" diameter. The actuator must provide proportional damper control in response to a 2 to 10 VDC or, with the addition of a 500Ω resistor, a 4 to 20 mA control input from an electronic controller or positioner. The actuators must be designed so that they may be used for either clockwise or counter-clockwise fail-safe operation. Actuators shall have control direction of rotation switch accessible on its cover. Actuators shall use a brushless DC motor controlled by a microprocessor and be protected from overload at all angles of rotation. Run time shall be constant, and independent of torque. A 2 to 10 VDC feedback signal shall be provided for position feedback or master-slave applications. Actuators shall be UL listed and CSA certified, have a 5 year warranty, and be manufactured under ISO 9001 International Quality Control Standards. Actuators shall be as manufactured by Belimo.

AF

**Note:** When using AF24-SR US actuators, only use accessories listed on this page.

**Wiring diagrams**

